

# ŠVESTKA

DEMOLICE • ZEMNÍ PRÁCE • NADROZMĚRNÁ PŘEPRAVA • MOBILNÍ JEŘÁBY • DOPRAVA • RECYKLACE

Liebherr L574 2+2

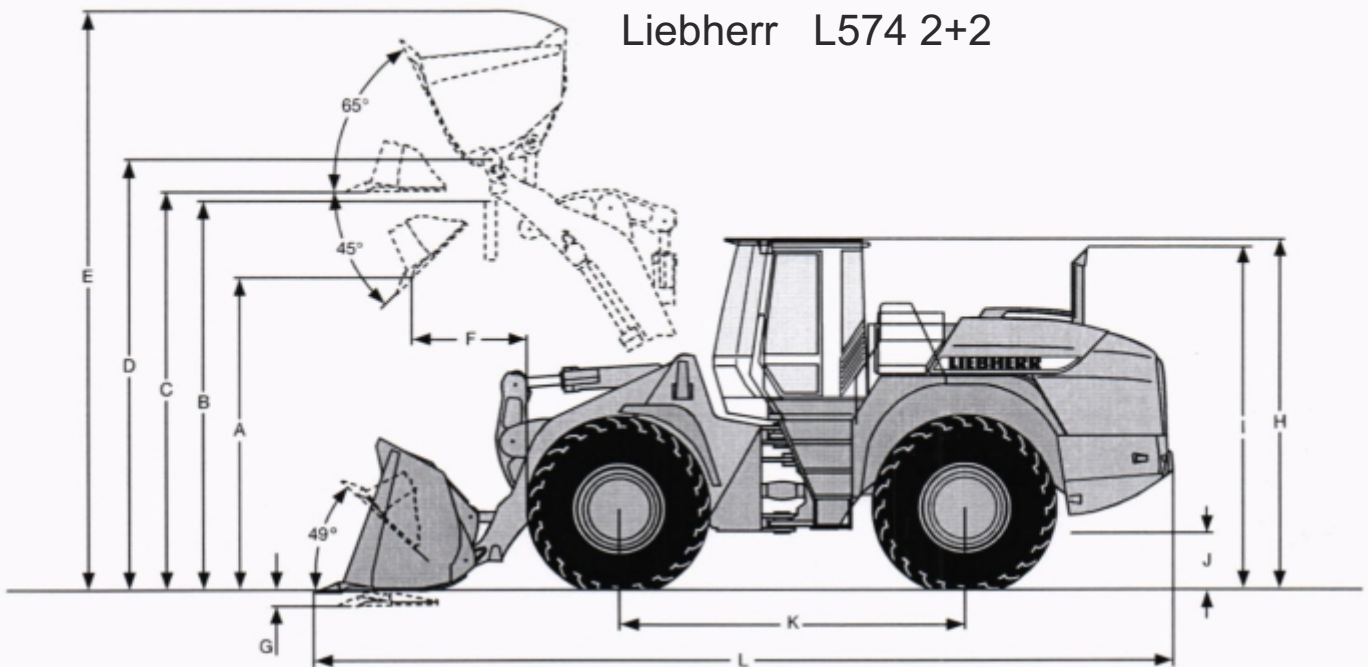

Bucket Type	L 574						L 574 S				
	Loading Bucket		Rock Bucket		Loading Bucket		Loading Bucket				
	T	T	E	T	E	T	T-Delta	T	T	T	
Cutting tools											
Bucket capacity	m <sup>3</sup>	4,5	4,5	4,5	5,0	5,0	4,0	4,0	4,5	4,5	5,0
Bucket width	mm	3000	3000	3000	3000	3000	3000	3000	3000	3000	3000
Specific material weight	t/m <sup>3</sup>	1,8	1,8	1,8	1,6	1,6	2,0	2,0	1,8	1,9	1,7
A Dumping height at max. lift height and 45° discharge	mm	3300	3385	3375	3300	3295	3440	3310	3080	3160	3080
B Dump-over height	mm	4100	4100	4100	4100	4100	4100	4100	3900	3900	3900
C Max. height of bucket bottom	mm	4255	4255	4255	4255	4255	4255	4255	4025	4025	4025
D Max. height of bucket pivot point	mm	4565	4565	4565	4565	4565	4565	4565	4355	4355	4355
E Max. operating height	mm	6320	6165	6165	6245	6245	6075	6075	6110	5945	6025
F Reach at max. lift height and 45° discharge	mm	1270	1185	1190	1270	1280	1125	1260	1325	1240	1325
G Digging depth	mm	110	110	110	110	110	110	110	100	100	100
H Height above cab	mm	3540	3540	3540	3540	3540	3540	3540	3540	3540	3540
I Height above exhaust	mm	3450	3450	3450	3450	3450	3450	3450	3450	3450	3450
J Ground clearance	mm	550	550	550	550	550	550	550	550	550	550
K Wheelbase	mm	3450	3450	3450	3450	3450	3450	3450	3450	3450	3450
L Overall length	mm	8980	8875	8695	8995	8815	8795	8980	8830	8710	8830
Turning circle radius over outside bucket edge	mm	7090	7020	6980	7050	7010	6995	6995	6990	6955	6990
Lifting force (SAE)	kN	250	250	250	250	250	250	250	245	250	245
Breakout force (SAE)	kN	175	190	190	175	175	203	175	175	190	175
Tipping load, straight*	kg	18350	19010	18810	18910	18710	19130	19080	19300	19890	19150
Tipping load, articulated at 37°*	kg	16400	16900	16710	16800	16620	16950	16890	17280	17800	17150
Tipping load, articulated at 40°*	kg	16100	16690	16510	16600	16425	16795	16750	16950	17460	16820
Operating weight*	kg	24250	24220	24420	24320	24520	24100	24150	24080	24060	24160

\* The figures shown here are valid with Michelin XHA 26.5R25 tyres and include all lubricants, a full fuel tank, the ROPS/FOPS cab and the operator.

Different tyres and optional equipment will change the operating weight and overturning loads.



= Rehandling bucket



= Loading bucket with back grading edge

T = Welded-on tooth holder with add-on teeth

T-Delta = Welded-on tooth holder on Delta cutting edge with add-on teeth

E = Four-piece, bolt-on reversible cutting edge

The attachments are secured directly to the lifting arms.

# ŠVESTKA

DEMOLICE • ZEMNÍ PRÁCE • NADROZMĚRNÁ PŘEPRAVA • MOBILNÍ JEŘÁBY • DOPRAVA • RECYKLACE

Liebherr L574 2+2

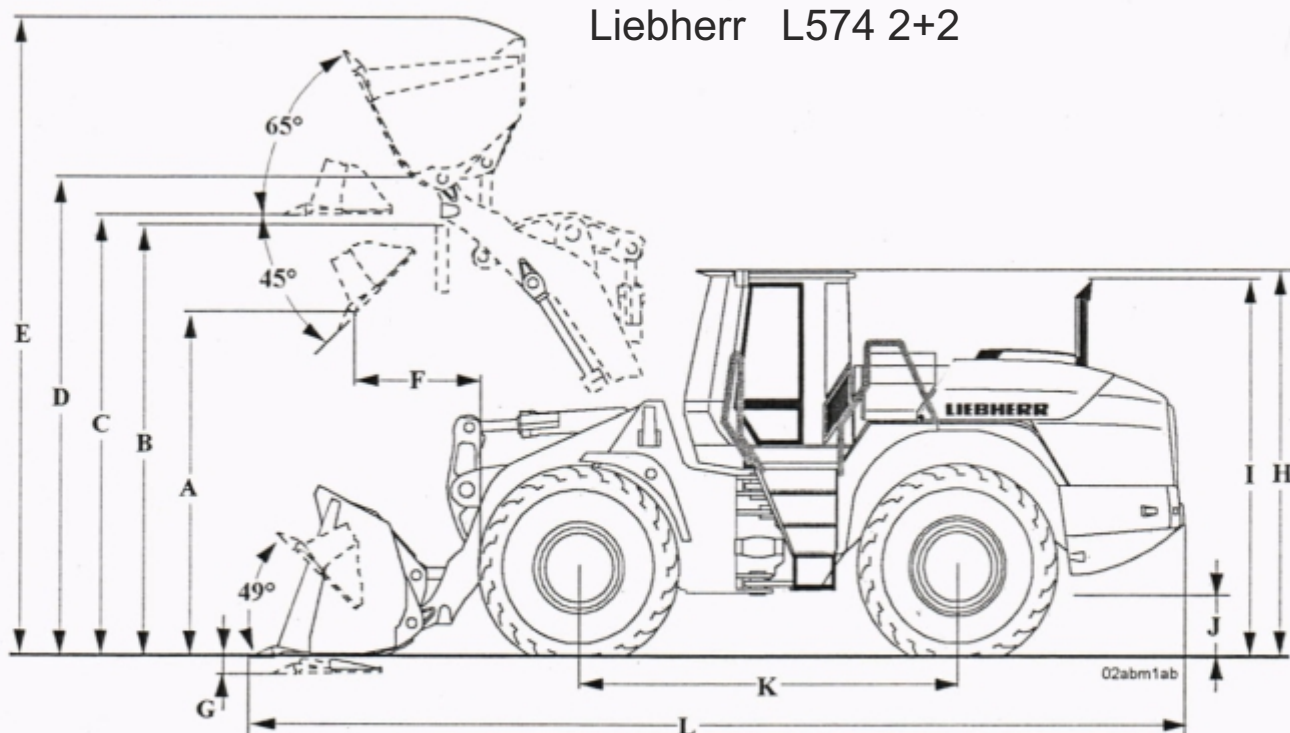

Abmessungen – Ausführung mit kurzem Z-Hubgerüst

Benennung	Wert	Wert	Einheit
Schaufelinhalt	4,5	5,0	m <sup>3</sup>
Schaufelbreite	3000	3000	mm
Spezifisches Schüttgewicht	1,9	1,7	t/m <sup>3</sup>
<b>A</b> Schütthöhe bei max. Hubhöhe und 45° Auskippwinkel	3160	3075	mm
B Überschüttbare Höhe	3900	3900	mm
<b>C</b> Max. Höhe Schaufelboden	4025	4025	mm
D Max. Höhe Schaufeldrehpunkt	4355	4355	mm
E Max. Höhe Schaufeloberkante	5945	6025	mm
F Reichweite bei max. Hubhöhe und 45° Auskippwinkel	1240	1325	mm
G Schürftiefe	100	100	mm
<b>H</b> Höhe über Kabine	3540	3540	mm
I Höhe über Auspuff	3450	3450	mm
J Bodenfreiheit	550	550	mm
K Achsabstand	3450	3450	mm
<b>L</b> Gesamtlänge	8710	8830	mm
Wenderadius über Schaufelaußenkante	6955	6990	mm
Hubkraft (SAE)	260	260	kN
Ausbrechkraft (SAE)	190	175	kN
Kipplast gerade	19890	19540	kg
Kipplast geknickt 37°	17800	17490	kg

L574-473/7477  
L574 S -473 /7477

**LIEBHERR**

1-7